

REV.	ZONE	LTR	DESCRIPTION	DATE	REVISER	APPD
------	------	-----	-------------	------	---------	------

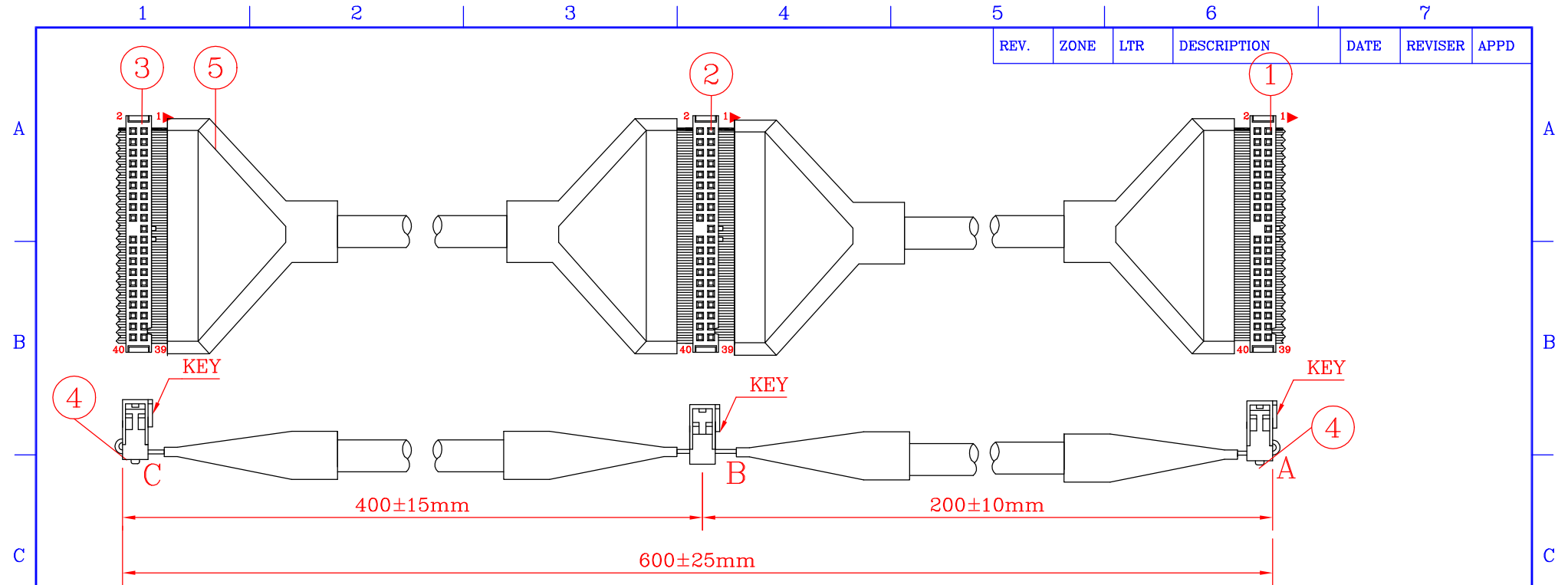

REMARK: BLACK PVC TUBE
(註記: 包覆黑色套管)

PIN ASSIGNMENT :

Conn A :	1	3	4	5	6	7	8	9	10	11	12	13	14	15	16	17	18
Conn B :	1	3	4	5	6	7	8	9	10	11	12	13	14	15	16	17	18
Conn C :	1	3	4	5	6	7	8	9	10	11	12	13	14	15	16	17	18
Conn A :	21	23	25	27	28	29	31	32	33	34	35	36	37	38	39		
Conn B :	21	23	25	27		29	31	32	33	34	35	36	37	38	39		
Conn C :	21	23	25	27	28	29	31	32	33		35	36	37	38	39		

GND :

Conn A	2,19,22,24,26,30,40
Conn B	2,19,22,24,26,30,40
Conn C	2,19,22,24,26,30,34,40

	780mm	ATAS TP CABLE	5	CFZ80-P-078
	2	ATAS SR	4	HIB40-SRZ
BLUE	1	ATAS IDC	3	HIB40F-Z3P
Gray	1	ATAS IDC	2	HIB40F-Z2P
BLACK	1	ATAS IDC	1	HIB40F-Z1P
REMARK	Q'TY	PART NAME	NO.	PART NO.

<p>高位企業有限公司 Yes Way Enterprise Corp.</p>		TOLERANCE UNSPECIFIED	
		.000	±
<p>SCALE</p> <p>1 : 1</p>	<p>UNIT</p> <p>mm</p>	.00	±
		.0	±
<p>NAME</p> <p>ATA100 CABLE ASSEMBLY</p>	<p>SHEET</p> <p>1 / 1</p>	.	±
		ANGLE	±
<p>DRAWING NO.</p> <p>A40A73-X060-B</p>	<p>REV</p> <p>0</p>	DRAWN Vivian 3/6/2002	
		DESIGNER Reo	
		CHECKED Jenny	
		APPROVED Tim	
		A3	